

SCHNITT A-A

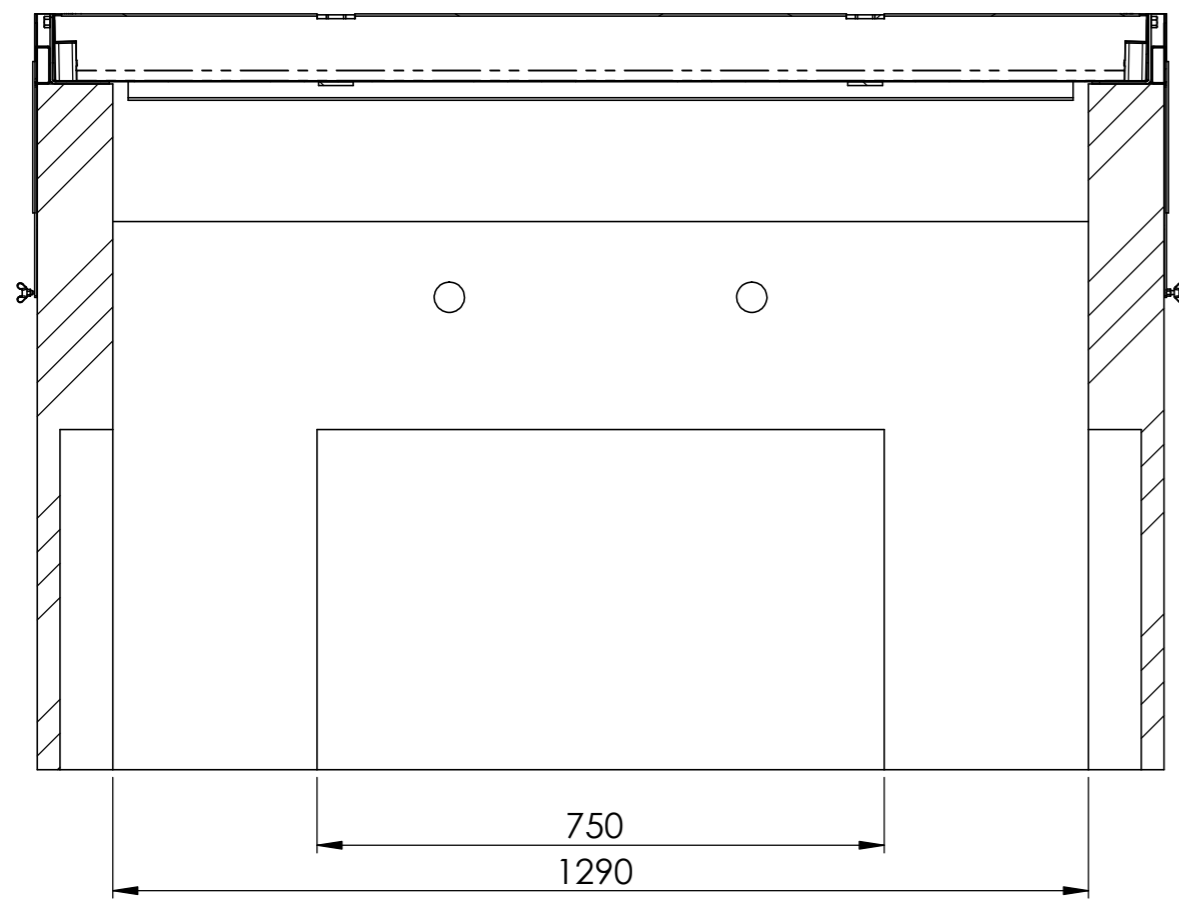
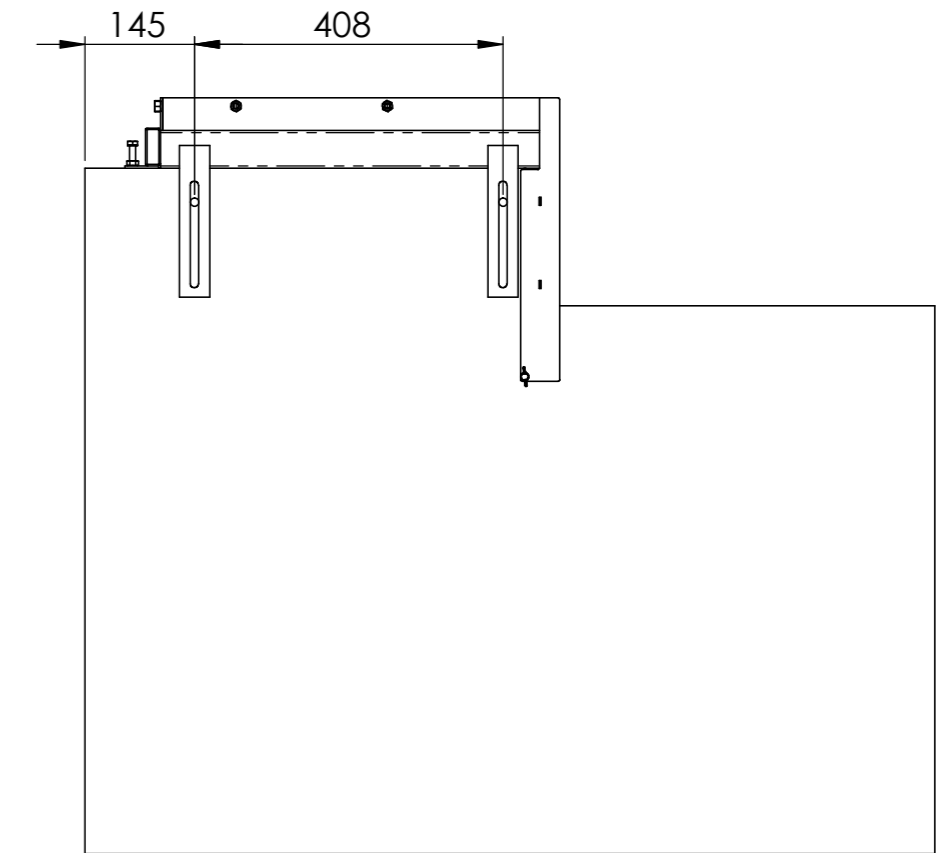

SCHNITT B-B

1x ECO.1005.D.B125
Optional A15 Variante mit Metaldeckel Mt.1005.D.ECO.A15

1x Rahmen FB13

1x Fundament FB13

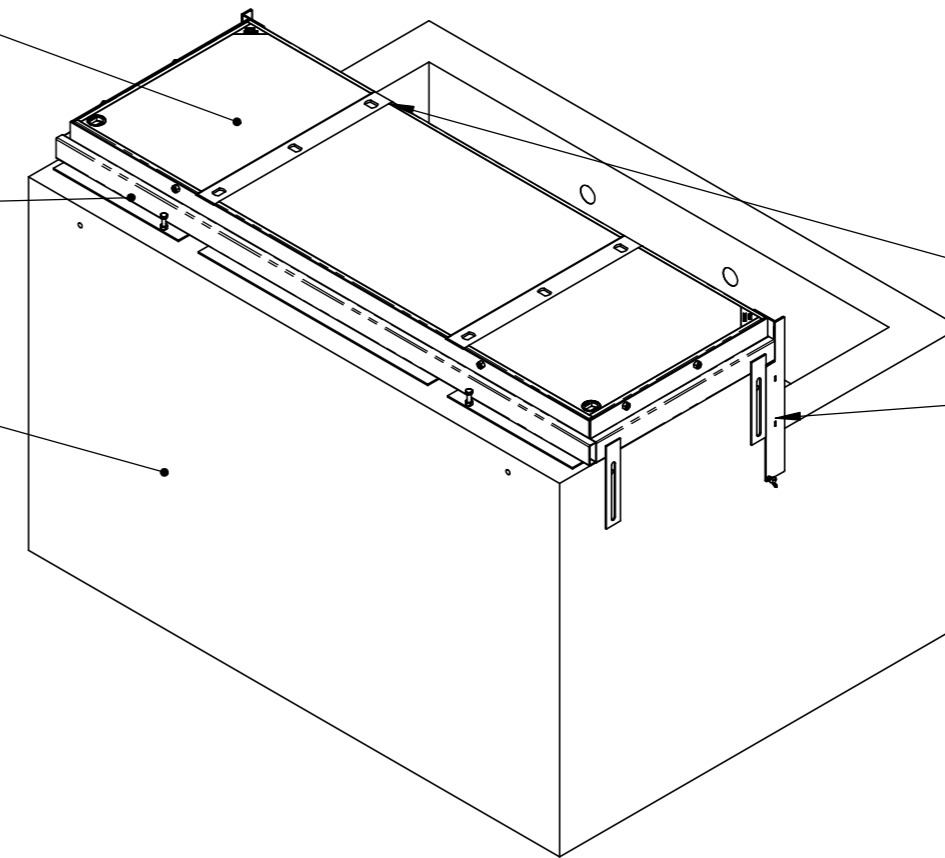

2x Kabinenhalterung

2x Schmutzschleuse

Allgemeintoleranzen ISO 2768-m		Material:		Gewicht: 825 Kg	
FB13 + Florida 13 Ohne Kabine B125/A15			Massstab 1:5	Gezeichnet	MH 16.12.2020
				Geprüft	MH 16.12.2020
			Format A2	Zeichnungsnr. 020-562	Datum Name

BETOX
Innovative Schachtsysteme